

MACHINE MODEL

# KTECH 1202 F3000

Double column automatic bandsaws for industry

Short description

KTECH 1202 is an automatic double column bandsaw suitable to cut bars, tubes, solids, profiles up to 60° both on left and right. An automatic sawing machine with CNC managed feeder and sawframe movement, KTECH has 10" touch screen display to manage the cutting process. The perfect working tool for professionals, big size production and industry application.



Scan the video

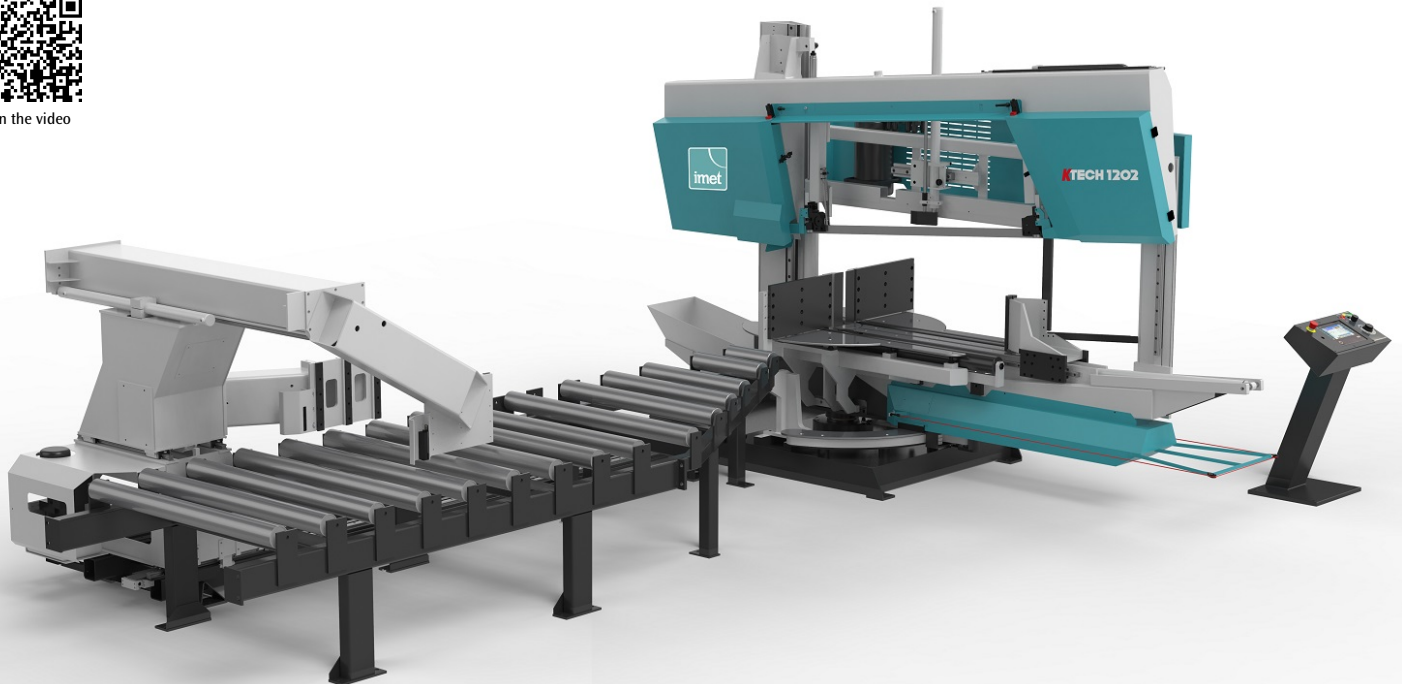

Cutting capacity at 90°	Round: 680mm - Square: 640mm - Rectangular: 1250x600mm
Cutting capacity at 45° (left)	Round: 680mm - Square: 600mm - Rectangular: 870x600mm
Cutting capacity at 45° (right)	Round: 680mm - Square: 600mm - Rectangular: 840x600mm
Cutting capacity at 60° (left)	Round: 580mm - Square: 530mm - Rectangular: 550x450mm
Cutting capacity at 60° (right)	Round: 550mm - Square: 450mm - Rectangular: 550x450mm
Cutting capacity with bundle device	Max: 1000x350mm - Min: 80x80mm - Scrap-end: 400mm
Cutting capacity at 90° (solid C45)	400mm
Blade size	8140x54x1.6mm
Blade tension	3000kg/cm <sup>2</sup>
Blade speed	18 - 90 m/min
Blade motor power	7.5KW
Feeder length	3000mm with automatic repetition
Minimum scrap-end	400mm
Cutting length	6 - 9.999mm
Feeder motor power	Asynchronous with inverter
Size - Weight	5750x4200x2750mm (h 850mm) - 4800kg

## Features



### 10" touch screen display

KTECH 1202 has an easy and intuitive interface dedicate to optimize the user-experience: thanks the CNC system and 10" touch screen display the user can manage all the machine operative function, set up 99 cutting program and multiple cutting length on the same bar, set the number of feeder stroke, the number of pieces and blade speed. It's also possibile to do an autodiagnostic to detect errors.



### CNC managed axes system

KTECH line automatic bandsaws have a CNC managed axes system (3 both for 802 and 1202 models: vice closing, material feeding and sawframe rotation) that can be set and controlled by touch screen (and SAWFACTORY).



### Sawframe

The electrowelded sawframe structure developed by our technicians has big thickness and allows to avoid vibrations and noise while working. Band pulleys are supported throught big size bearings with metal plate to have the better alignment. Sawframe movement perfectly balanced by big diameter hydraulic cylinder and linear guides.



### Accuracy and precision

IMET automatic and semiautomatic bandsaws uses an innovative angle measurement system located outside the machine center so that the angle precision and accuracy is always as high as possible, even on left and right angular cuts.

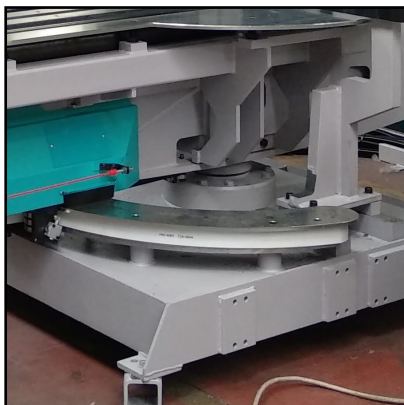

### Motorized sawframe rotation

IMET's KTECH and KS NC bandsaws has a CNC managed and motorized sawframe rotation system (where all the parameters can be set by touch screen display. Sawframe rotation is made possibile by an hydraulic cylinder

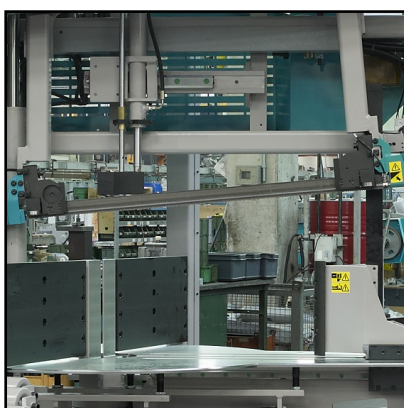

### Cambed blade

To increase material penetration, avoid loweing slowdown and save blade life, KTECH machines have a 5° cambed blade that helps to optimize the cutting process even on bigger and stroger profiles.



### Blade tension

Blade tension is managed by a mechanic/hydraulic system. Ideal blade tension (which is 3000kg/cm<sup>2</sup>) can be set via touch screen display and machine software. If a breakage happens, Ktech software immediately stops the process, allowing maintenance.

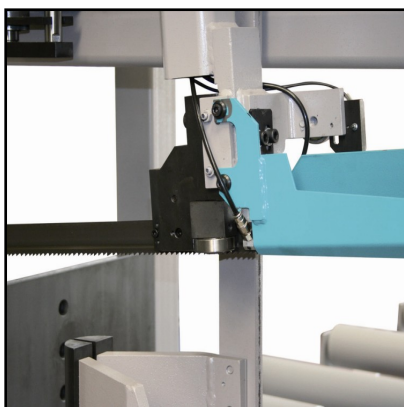

### Blade guides

Hard metal blade guides with lateral guide cemented rolls, hardened and rectificated with easy regulation system. Mobile blade guides is auomatically kept next to the cutting area for a better blade alignment and highest precision.



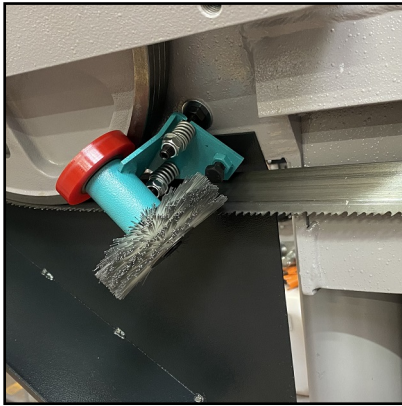

## Blade cleaning

An adjustable and mechanic motorized metal cleaning brush provides to remove residuals and remainings on the blade while cutting. Minimal lubrication is a standard equipend to avoid liquid dispersion that could affect the length measurement.



## Vice

Horizontal vice with round jaws so that the material can be locked on every set angle. This design allows to lock the material as close as possible to the cutting line on both bar sides, easing the process on every angle. Jaws height is 370mm.



## Feeder

KTECH has an integrated feeder with integrated roller table, length 3000mm. Feeder movement and repetition are set via touch screen display. Cutting material is fullu supported by the roller table, while final scrap-end is 150mm.

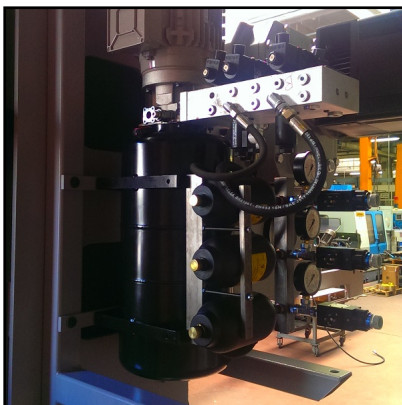

## Hydraulic unit

Hydraulic unit of new design with new low noise pump and locking valves on all the movements, with vice pressure reducers. Most processes are carried out with switched off hydraulic unit that allows a considerable saving of energy and maintains low the oil temperature.



### Minimal lubrication system

Standard minimal lubrication keep the material dry, avoiding wastes. The system can work in 3 ways: always switched-on, switched-on only while cutting, switched-off. If the oli isn't enough, it's reported on the machine display.



### SAWFACTORY - INDUSTRY 4.0 Ready (Optional)

**OPTIONAL**

IMET automatic machines can be connected to the company network and be used remotely thanks SAWFACTORY and modem. SAWFACTORY is a dedicated software which allows to manage the cutting process from the office desk by setting cutting programs and monitoring the workflow thanks to the dedicated web app. The software also allows to also receive assistance by our technicians remotely. Discover SAWFACTORY: <https://bit.ly/2RuxHuX>

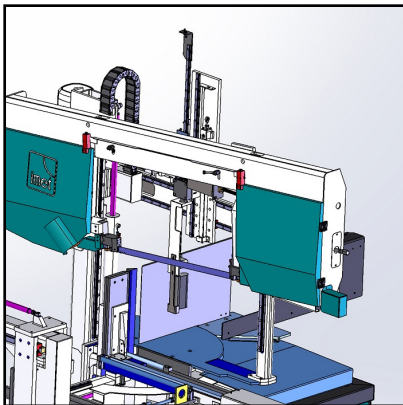

### Marking system (Optional)

**OPTIONAL**

It's available for KTECH models the automatic ink marking system that allows to impress a code on cut pieces to ease the material selection after the cut: the marking systems works before the cut and its programming is integrated with the machine CNC (allowing to create a unique program via KTECH touch screen) but it's equipped with its own independent touch screen display.



### Blade deviation control (Optional)

**OPTIONAL**

It allows to always have cutting process with the right tolerance. It's possible to set the preferred tolerance based on the needs for a specific material or cutting angle (maximum tolerance: 0.2mm).



**Laser ray (Optional)**

**OPTIONAL**

To ease the working process, it's possibile to require di special laser ray that points the cutting line on the material before starting to operate.

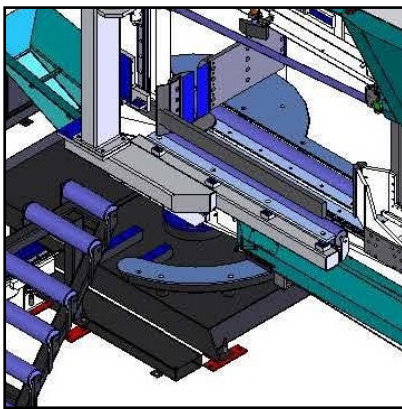

**Bundle cutting device (Optional)**

**OPTIONAL**

Hydraulic bundle cutting device. Applying the device, the maximum cutting capacity is 1000x320mm while the minimum capacity is 80x80mm. Minimum scrap-end with bundle: 400mm. If the user wants to use the machine for mitre cutting, the device must be disassembled.

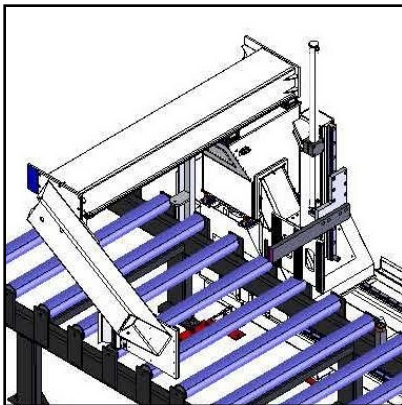

**Bundle cutting device (Optional)**

**OPTIONAL**

Together with the pressure placed next to the vice, the bundle cutting is made also by a supplementary device placed on the integrated feeder on outer part of feeder's jaws. This device must not be removed to use mitre cutting.



**Metal protection barriers (Optional)**

**OPTIONAL**

According to CE law, it's also available the protection safety system made by metallic barriers that covers the machine on the 4 side with CNC managed access doors to regulate and control the operator access to the working area.





**Safety photocells (Optional)**

**OPTIONAL**

It's possible, if the user doesn't want a full metallic barriers protection system, to install a pair of photocells instead of one of the metallic side.



**Loading/unloading roller table (Optional)**

**OPTIONAL**

Loading and unloading roller table with free rolls, 2 vertical containment rolls on one side. Module length 2m

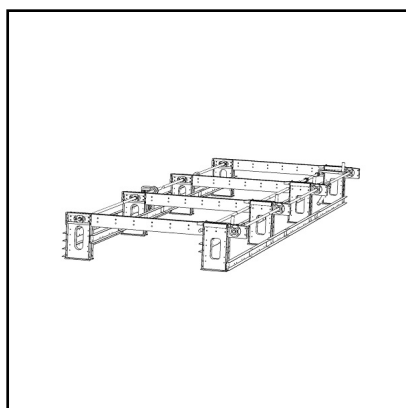

**Automatic loading system (Optional)**

**OPTIONAL**

Automatic bar loader driven by the saw control software where the bars are automatically fed, consisting of supporting surfaces with a drag chain and loading stations (from 5 to 15). The supporting surfaces can be easily moved thanks to a modular structure. The feeder is provided with a system of blockage of the bar and with vertical aligning rollers and gearboxes to move the drag chains. The system is driven by the software of the saw to which it is connected.

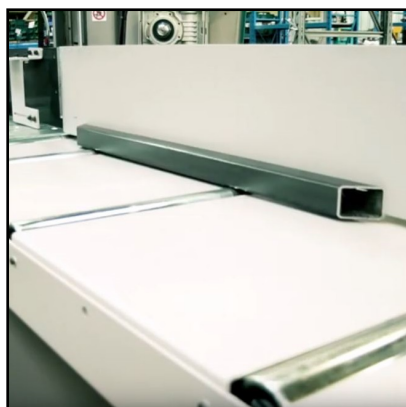

**Automatic unloading system (Optional)**

**OPTIONAL**

Upon request it's available a customized material unloading system with bar warehouse developed based on the customer requests and needs.