

MACHINE MODEL

SIRIO 370 SH-E

Heavy duty semiautomatic vertical saw

Short description

SIRIO 370 is the semi-automatic vertical miter saw for cutting solids and steel profiles also with high resistance; by applying the ESC speed variator, the range of materials go from steel to stainless steel and light alloys. The machine can cut from 0 ° to 45 ° right and from 0 ° to 60 ° left.



Scan the video

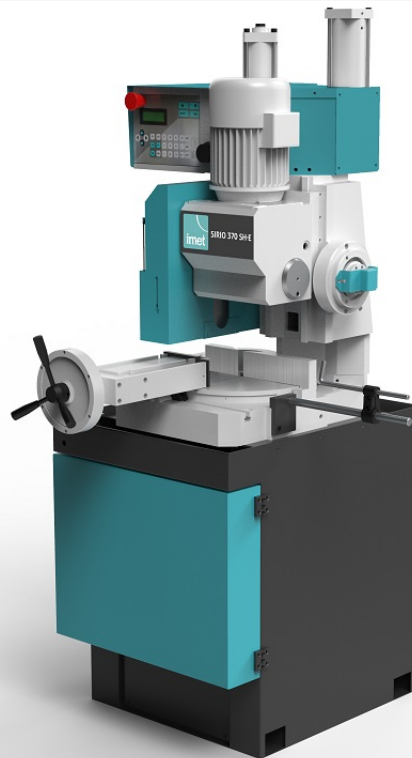

Dimensions	810x1080x2100mm
Weight	443kg
Cutting capacity at 0°	Round: 120mm - Square: 100mm - Rectangular: 180x100mm
Cutting capacity at 45° left	Round: 120mm - Square: 100mm - Rectangular: 0x100mm
Cutting capacity at 45° right	Round: 105mm - Square: 100mm - Rectangular: 0x100mm
Cutting capacity at 60° left	Round: 110mm - Square: 90mm - Rectangular: x100mm
Cutting capacity (for solids)	Round: 0°: 80mm
Blade dimensions	Diam.: 370mm
Blade hole	40mm
Blade speed	15/70 rpm
Blade motor power	3KW
Working table height	925mm

Features



Structure

The SIRIO models have high structural stability to reduce vibrations and movements of the miter saw when cutting. The rigid vertical structure is in cast iron with a large surface of contact between the machine head and the structure to ensure even more solidity when in use



Cutting precision

SIRIO is equipped with a system with adjustable stops at 0 ° and 45 °, adjustable bar stop and graduated scale for other angles and maximum positioning precision.



SH-E version

SIRIO 370 SH-E is a semi-automatic machine with electro-pneumatic operation and hydraulic control. Programming of the operator parameters and management of the cut are made by the control panel.

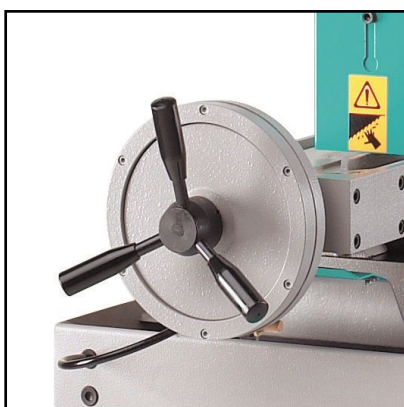

Pneumatic vice

The semi-automatic disc cutting-off machines Sirio are fitted as standard with the pneumatic front vice with material locking and transversal movement on the work surface.



Device to synchronize the RTD/RTP table and the head motion
Device to synchronize the RTD/RTP table and the head motion

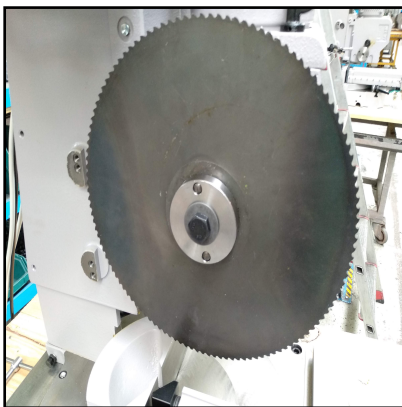

Blade (Optional) **OPTIONAL**

Sirio 370 mount a blade 370X3X40



V JAWS (Optional) **OPTIONAL**

Two pairs of cast iron V jaws to fittings bundles and round bars (max diameter 85 mm.) with tools to mount them



Minimal lubrication system (Optional) **OPTIONAL**

The lubrication system cancels the dispersion of the coolant without damaging or affecting the life of the blade. The system is equipped with a 1.3l tank and nozzle.

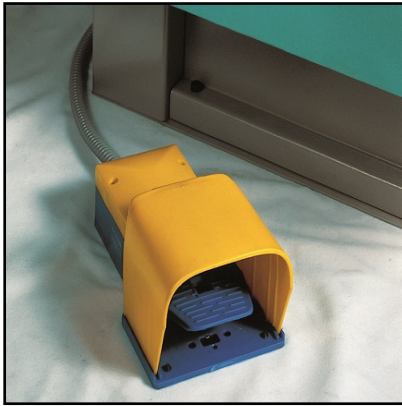

Foot pedal (Optional)

OPTIONAL

FOOT PEDAL+CABLE 3M + PLUG



Connection for tables (Optional)

OPTIONAL

Connection for loading/unloading table



Loading/Unloading roller tables 1st unit (Optional)

OPTIONAL

1st unit of roller conveyor compatible for both the loading and unloading sides.
Length 2m, loading capacity 700kg.



Loading/Unloading roller tables follow.unit (Optional)

OPTIONAL

Following unit of roller conveyor compatible for both the loading and unloading sides. Length:2m, loading capacity:600kg.

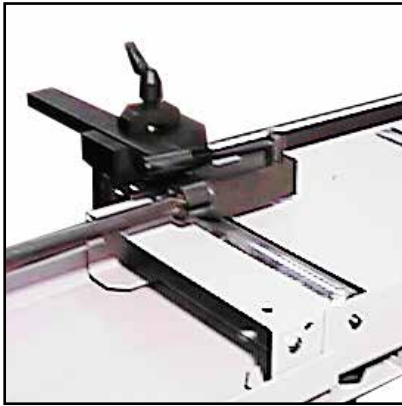

Unloading roller table with metric rod 1st unit (Optional) OPTIONAL

1° unit of roller conveyor (unloading side) with metric rod and length stop. Length: 2m, loading capacity 700kg.

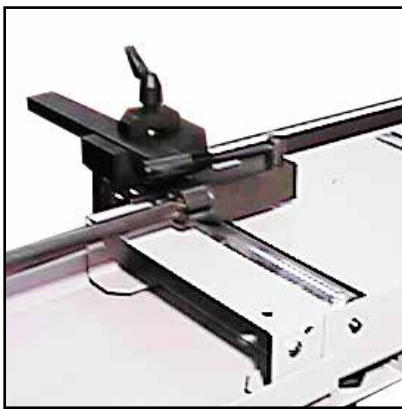

Unloading roller table with metric rod follow.unit (Optional) OPTIONAL

Following unit of roller conveyor (unloading side) with metric rod and length stop. Length: 2m, loading capacity 600kg.



Unloading table with digital reading and manual positioning (Optional) OPTIONAL

Unloading table with digital reading and manual positioning, you can choose lengths of 2mt., 4mt., 6mt., 8mt., 10mt., 12mt.....



Unloading roller table with length stop (optional) OPTIONAL

Unloading roller table with length stop and selection of the lengths by means of a keyboard Available: -RTP3W30: Measuring length of 3m, 3 pedestals, max loading 3000kg; -RTP6w30: Measuring length of 6m, 5 pedestals, max loading 6000kg. etc..

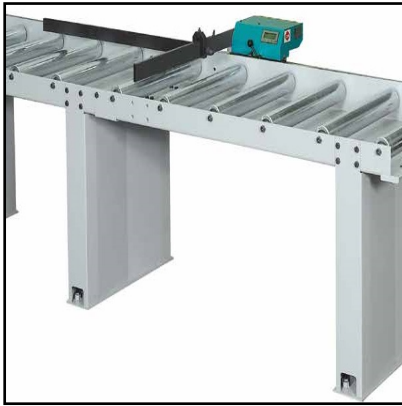

Unloading roller table with digital reading and manual **OPTIONAL**

Unloading roller table with digital reading and manual movement. Available : n -RTL3W30 Measuring length of 3m, 3 pedestals, max loading 3000kg; -RTL6KW30 Measuring length of 6m, 5 pedestals, max loading 6000kg. etc..



Vertical rollers(Optional) **OPTIONAL**

Pair of containment vertical rollers 300 mm made in steel, max 2 pairs for each element 2 m long; to use without rollers cover (only for RTS) (not available together with RV-W30)



V rollers (Optional) **OPTIONAL**

Pairs of V rollers made in steel for tubes, max 6 pairs per each element 2 m long, to be used on machines with V jaws, without rollers cover (only for RTS) (not available together with RI-W30) Pair of containment vertical rollers 300 mm made in steel, max 2 pairs for each element