

ULTRA  
SERIES

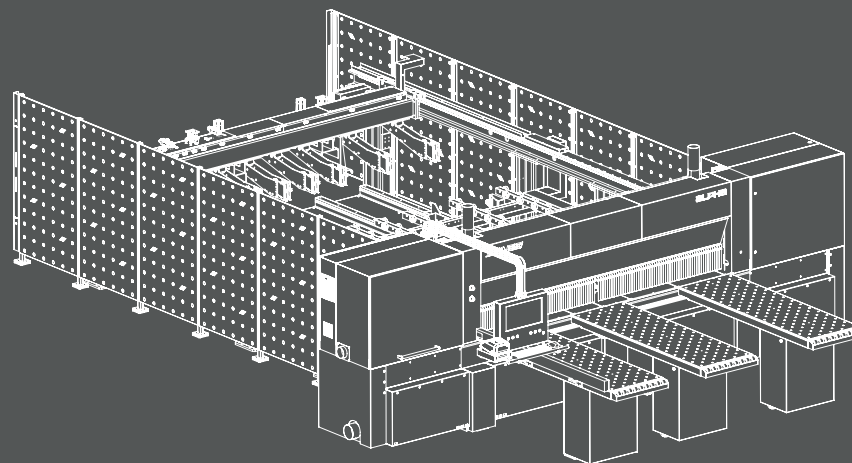

**ALPHA**  
PS - 05 / 06



EN  
TR  
ES

Making its first overseas investment in the USA as the flagship of the Turkish woodworking machinery industry, AES continues to serve its customers in the North and South America through its center that was launched in Charlotte, North Carolina to provide sales and aftersales services.

Türk ahşap işleme sektörünün bayrak taşıyıcı firması olarak, ABD'de ilk yurt dışı yatırımını yapan AES satış ve satış sonrası hizmetleri için N.Carolina/Charlotte'da aktif hale getirdiği merkezi ile, Kuzey ve Güney Amerika'da hizmet vermeyi sürdürmektedir.

Haciendo su primera inversión en el extranjero en los EE. UU. como el buque insignia de la industria de maquinaria de carpintería turca, AES continúa sirviendo a sus clientes en América del Norte y del Sur a través de su centro que se inauguró en Charlotte, Carolina del Norte para brindar servicios de ventas y posventa.

As part of its policy to expand its sales and aftersales service network on an ongoing basis, AES has incorporated its affiliate AES Europe in Bilzen, Belgium with a view to providing better sales and aftersales services as well as technical support to its customers in Europe

Avrupa kıtasındaki müşterilerine daha iyi satış ve satış sonrası hizmet verebilmek amacıyla Bilzen/Belçika'da AES Europe'u kurdu AES, müşterilerine teknik destek sağlarken satış ve servis ağını da her geçen gün büyümeye devam etmektedir.

Con el fin de brindar un mejor servicio de venta y posventa a sus clientes en el continente europeo, AES que estableció AES Europe en Bilzen/Bélgica, mientras brinda soporte técnico a sus clientes, continúa expandiendo su red de ventas y servicio día a día.

AES GROUP, which has redefined the sector with the machines and designs it has developed in the Woodworking Machinery sector since the first day it was founded in 1989; It is the flag carrier company of Turkey in the sector. AES, which always continues to be your global partner with its high production capacity, expert staff, global sales and service network, grows with you and continues to develop while growing, with the centers it opened and the service network it established to become one of the world's leading manufacturers in line with its founding vision.

1989 yılında, kurulduğu ilk günden bu yana Ahşap İşleme Makineleri sektöründe geliştirdiği makineler ve tasarımlarla AES GROUP; Türkiye'nin sektördeki bayrak taşıyıcı firması konumundadır. Yüksek üretim kapasitesi, uzman kadrosu, küresel satış ve servis ağı ile her zaman global partneriniz olmaya devam eden AES, kuruluş vizyonu doğrultusunda, dünyanın sayılı üreticileri arasında girmek için açtığı merkezler ve kurduğu hizmet ağı ile; sizlerle büyüyor, büyürken de geliştirmeye devam ediyor.

GRUPO AES, que ha redefinido el sector con las máquinas y diseños que ha desarrollado en el sector de la Maquinaria para la Madera desde el primer día de su fundación en 1989; Es la compañía aérea de bandera de Turquía en el sector. AES, que siempre sigue siendo su socio global con su alta capacidad de producción, personal experto, red global de ventas y servicio, crece con usted y continúa desarrollándose mientras crece, con los centros que abrió y la red de servicio que estableció para convertirse en uno de los principales fabricantes del mundo en consonancia con su visión fundacional.

*your global partner*

AES Group; It grows with you with the goal of becoming a global brand and continues to produce and develop while growing. AES UK continues its Sales and After-Sales Service services in the UK, Ireland, Northern Ireland, Scotland and Wales regions.

AES Group; küresel bir marka olma hedefi ile sizlerle büyümekte, büyürken de üretmeye ve geliştirmeye devam etmektedir. AES UK firması ile Britanya, İrlanda, Kuzey İrlanda, İskoçya ve Galler bölgelerinde Satış ve Satış Sonrası Servis hizmetlerini sürdürmektedir.

Grupo AES; Crece contigo con el objetivo de convertirse en una marca global y continúa produciendo y desarrollándose mientras crece. AES UK continúa con sus servicios de Ventas y Servicio Posventa en las regiones del Reino Unido, Irlanda, Irlanda del Norte, Escocia y Gales.

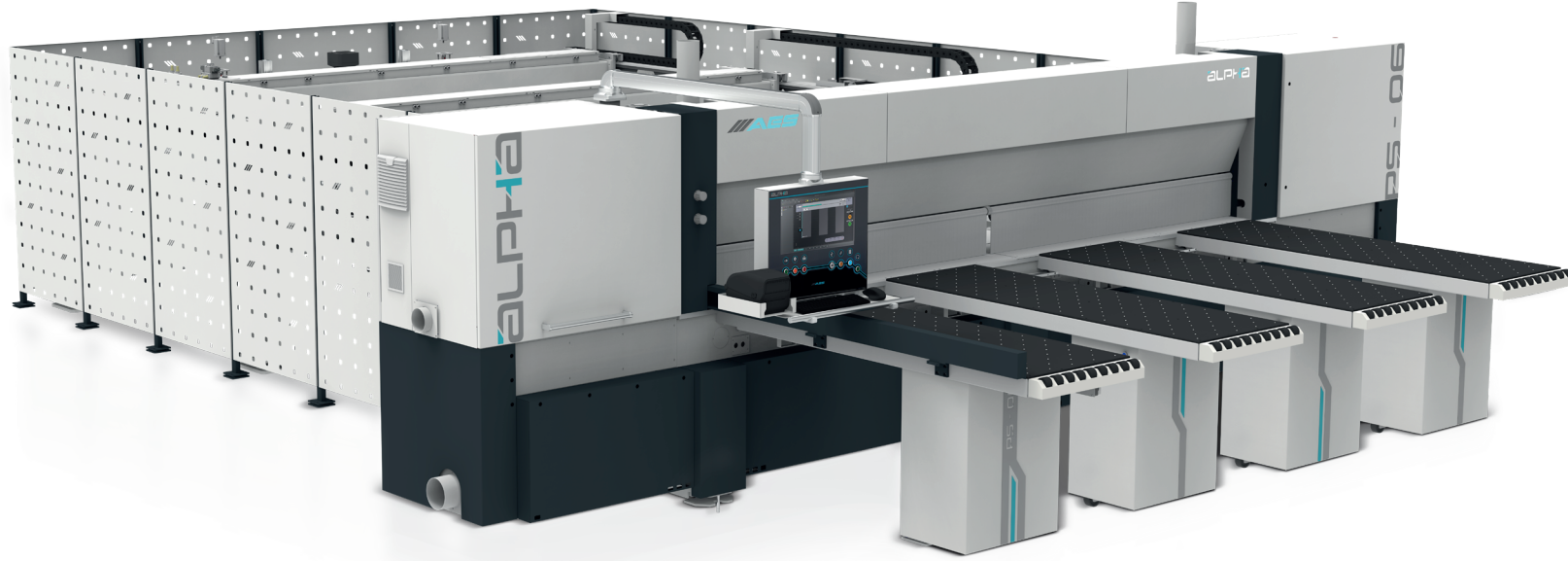

PS-05  
PS-06

3300  
3300 x 3300 mm

3900  
3900 x 3900 mm

4300  
4300 x 4300 mm

# UltraPower

Performance

Ultra güç, ultra performans  
Ultra potencia Ultra rendimiento

EN

Our ULTRA series machinery offers industrial solutions to provide maximum performance even for the most delicate designs and processes. The ULTRA series will support you for all your needs with its flexible configuration, optimizing operation speed and precision thanks to its gantry system allowing for excellent acceleration. It ensures that you achieve the best machining results you could imagine thanks to its body structure eliminating even the slightest vibrations.

TR

Endüstriyel çözümler sunan ULTRA serisi makinelerimiz ile en hassas tasarım ve işlemlere dahi tam performans çözümler sunar. Esnek konfigürasyonu sayesinde tüm ihtiyaçlarınız için yanınızda olan ULTRA serisi; Gantry sistemi ile makine çalışma hızı ve hassasiyetini optimum seviyeye çıkararak mükemmel işlemeye olanak sağlar. En küçük vibrasyonun dahi engellendiği gövde yapısı sayesinde işleme esnasında size hayalinizdeki sonucu garanti eder.

ES

Con nuestras máquinas de la serie ULTRA que ofrecen soluciones industriales, ofrecemos soluciones de rendimiento completo incluso para los diseños y procesos más sensibles. Gracias a su configuración flexible, el sistema Gantry de la serie ULTRA, que le apoya para todas sus necesidades, proporciona una excelente aceleración al optimizar la velocidad de trabajo y la precisión de la máquina. Gracias a su estructura del cuerpo que evita hasta la mínima vibración, le garantiza el resultado de sus sueños durante el procesamiento.



# Built For Toughest Situations

ALPHA beam saw machine is designed to perform panel processing applications in the most efficient manner. It guarantees precise and error-free results thanks to its strong body and fast structure.

ALPHA Panel Ebatlama makinesi, panel işleme uygulamalarını en verimli şekilde yapmak için tasarlandı. Güçlü gövde ve hızlı yapısı ile hassas ve hatasız sonuçları garanti eder.

ALPHA La máquina con seccionadoras está diseñada para realizar aplicaciones de procesamiento de paneles de la manera más eficiente. Garantiza resultados precisos y sin errores gracias a su cuerpo fuerte y estructura rápida.



# High Performance Perfect Result

Yüksek performans,  
mükemmel sonuç  
*Excelente resultado con  
alto rendimiento*

## HIGH PERFORMANCE SAW CARRIAGE UNIT

### YÜKSEK PERFORMANSLI TESTERE ÜNİTESİ

UNIDAD DE SIERRA DE ALTO RENDIMIENTO

EN With a saw blade motor of 18 or 27 kW, 3 kW scoring saw motor ensures fast precise and safe cutting. It works optimally with minimum cost with its strong structure.

TR 18 ve 27 kW işleme gücüne sahip testere grubu ile, 3 kW çizici testere motoru hızlı, hassas ve güvenli kesim sunar. Güçlü yapısı ile minimum maliyet ile optimum şekilde çalışır.

ES Con su grupo de sierra que tiene potencia de procesamiento 18 y 27 kW, el motor de sierra de trazador 3 kW garantiza un corte rápido, preciso y seguro. Funciona óptima a un coste mínimo con su estructura potente.

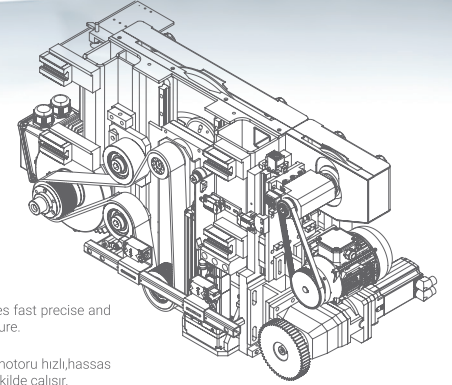

EN Additional options for grooving operations.

TR Kanal açma özelliği işlemlerinizi için ek opsiyonlar

ES Opciones adicionales para las operaciones de función de apertura de canal

## FAST & PRACTICAL SAW CHANGE

### HIZLI & PRATİK TESTERE DEĞİŞİMİ

RÁPIDO Y PRÁCTICO CAMBIO DE SIERRA



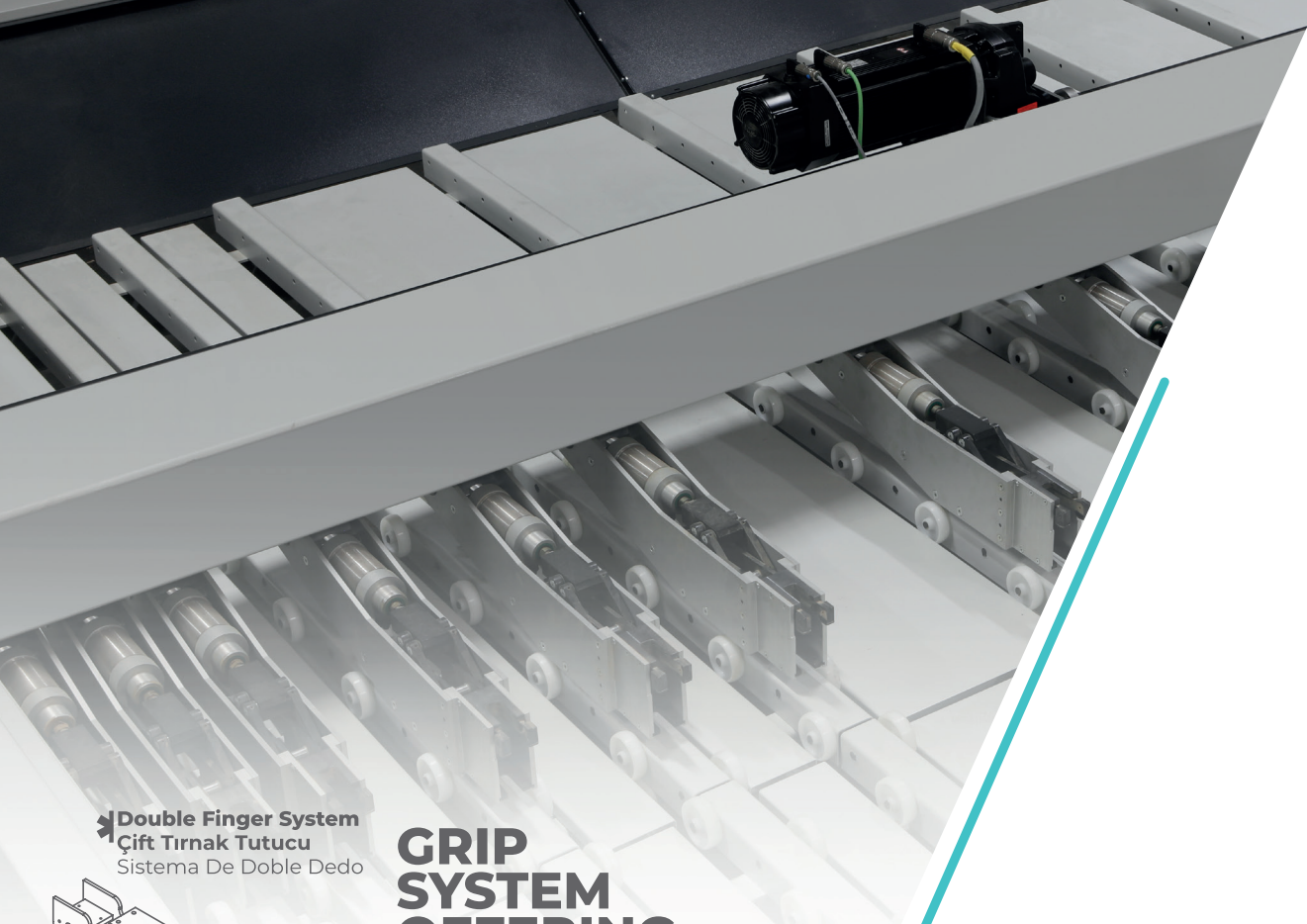

## AIR FLOATING WORKING TABLE FOR EASY LOADING

### KOLAY YÜKLEME İÇİN HAVA YÜZDÜRMELİ TABLA

MESA FLOTANTE DE AIRE PARA FACILITAR LA CARGA

EN The working table on Alpha allows for easy loading and unloading with its ergonomic structure.

TR Alpha'da bulunan çalışma tablası ergonomik yapısı ile kolay yükleme ve boşaltmaya imkan sağlar.

ES La mesa de trabajo en Alpha permite cargar y descargar fácilmente con su estructura ergonómica.

Double Finger System  
Çift Tırnak Tutucu  
Sistema De Doble Dedo

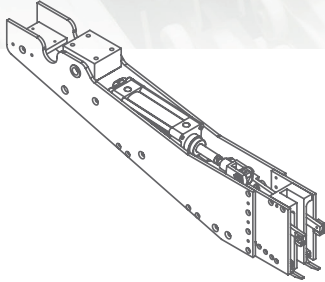

## GRIP SYSTEM OFFERING EXCELLENT PRECISION

### MÜKEMMEL HASSASİYET SUNAN TUTUCU SİSTEM

SISTEMAS DE PORTADOR QUE GARANTIZA LA PRECISIÓN DE ALTO NIVEL

EN With a saw blade motor of 18 or 27 kW, 3 kW scoring saw motor ensures fast precise and safe cutting. It works optimally with minimum cost with its strong structure.

TR 18 ve 27 kW işleme gücüne sahip testere grubu ile, 3 kW çizici testere motoru hızlı, hassas ve güvenli kesim sunar. Güçlü yapısı ile minimum maliyet ile optimum şekilde çalışır.

ES Con su grupo de sierra que tiene potencia de procesamiento 18 y 27 kW, el motor de sierra de trazador 3 kW garantiza un corte rápido, preciso y seguro. Funciona óptima a un coste mínimo con su estructura potente.



Barcode Printer  
Barkod Yazıcı  
De Código De Barras

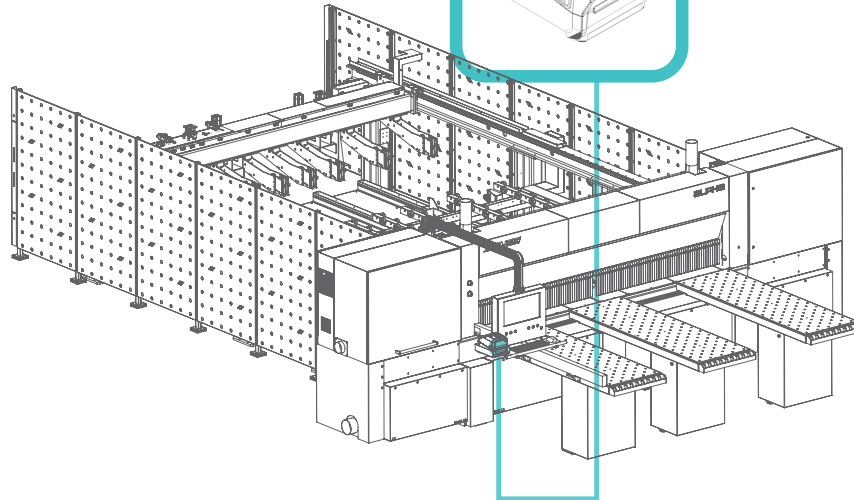

#### CENTRAL LUBRICATION UNIT

Automatically lubricates the main components in 21 different zones

#### MERKEZİ YAĞLAMA ÜNİTESİ

21 farklı bölgede ana aksamların otomatik olarak yağlanmasını sağlar.

#### UNIDAD CENTRAL DE LUBRICACIÓN

Permite la lubricación automática de los componentes principales en 21 regiones diferentes.



#### AXIS CONTROL WITH SERVO MOTORS

State of the art motors located on each axis ensure precise acceleration at high speed

#### SERVO MOTORLAR İLE EKSEN KONTROLÜ

Tüm eksenlerde bulunan son teknoloji ürünü motorlar, yüksek hızlarda hassas ivmelenme sağlar

#### CONTROL DE EJES CON SERVOMOTORES

Los motores de última generación en todos los ejes proporcionan una aceleración precisa a altas velocidades

# Details Considerate for your Business

İşiniz için  
düşünmüş detaylar  
Detalles considerados  
para su negocio

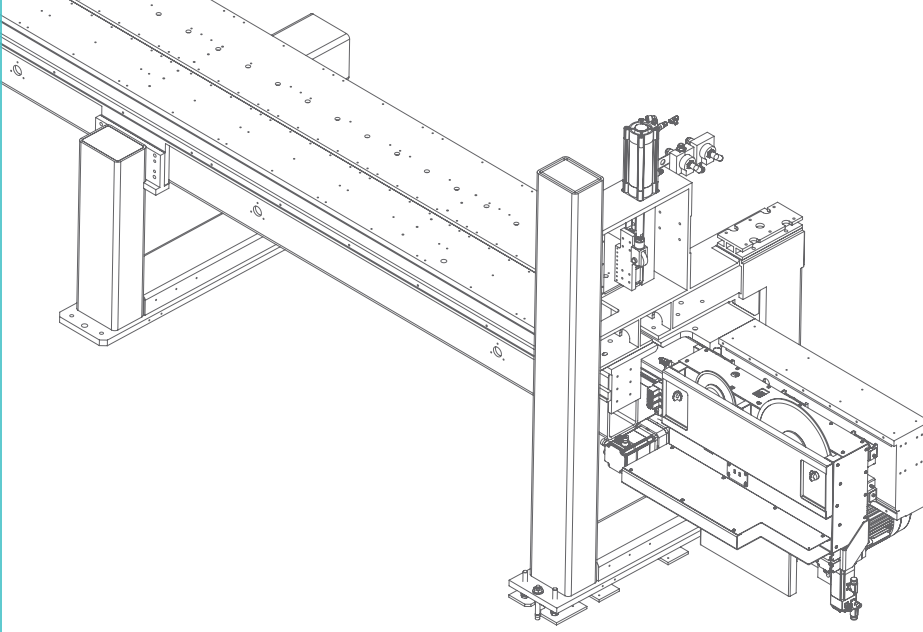

## STRONG BODY GÜÇLÜ GÖVDE

CUERPO FUERTE

- EN** The machine body is made of fully vibrated steel, its strong body structure allows for smooth production even under the most challenging conditions.
- TR** Makine gövdesi tamamen titreşimi alınmış çelikten üretilmiştir, güçlü gövde yapısı en zorlu şartlarda dahi sorunsuz üretim yapılabilmesine imkan sağlar.
- ES** La carrocería de máquina está fabricada de un acero no vibrantes completamente y su carrocería potente permite que se haga producción aun bajo las condiciones más difíciles.

## UNINTERRUPTED PRODUCTION WITH THE LIFT UNIT

LIFT ÜNİTESİ İLE  
KESİNTİSİZ ÜRETİM

PRODUCCIÓN ININTERRUMPIDA CON LA UNIDAD DE  
ELEVACIÓN

- EN** The lift unit option offered on the ALPHA allows you to keep plates ready for the processing sequence. The lifting unit positioned on the side of the table has a load capacity of 500 mm. Elevator parts are easily carried onto the air float table. In this way, operator safety and time savings are guaranteed.
- TR** ALPHA'da sunulan lift ünitesi, plakaları işlem sırası için hazır tutmanızı sağlar. Tablanın arka tarafına konumlandırılan lift ünitesi 500 mm yüklem kapasitesine sahiptir. Lift üzerindeki parçalar kolayca hava yüzdürmeli tabla üzerine alınır. Böylece zaman tasarrufu ile birlikte operatör güvenliği sağlanmış olur.
- ES** La opción de unidad de elevación que se ofrece en ALPHA le permite mantener las placas listas para la secuencia de procesamiento. La unidad de elevación posicionada en el lateral de la mesa tiene una capacidad de carga de 500 mm. Las piezas del elevador se llevan fácilmente a la mesa de flotante de aire. De esta manera, se garantizan la seguridad del operador y el ahorro de tiempo.

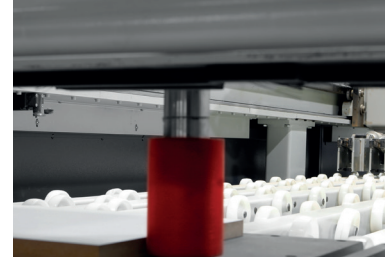

## EXCELLENT ALIGNMENT

MÜKEMMEL  
HİZALAMA

EXCELENTE ALINEACIÓN

- EN** The side aligner unit is used to align the parts to be cut. The unit aligns area between 50-2350 mm. with servo control.
- TR** Yan parça dayama kesilecek parçaların hizalamasını yapmak için kullanılır. Ünite 50-2350 mm. alanda servo motor ile hassas hizalama yapmaktadır.
- ES** La unidad de alineación lateral se utiliza para alinear las piezas que se van a cortar. La unidad alinea el área entre 50 y 2350 mm con servocontrol.

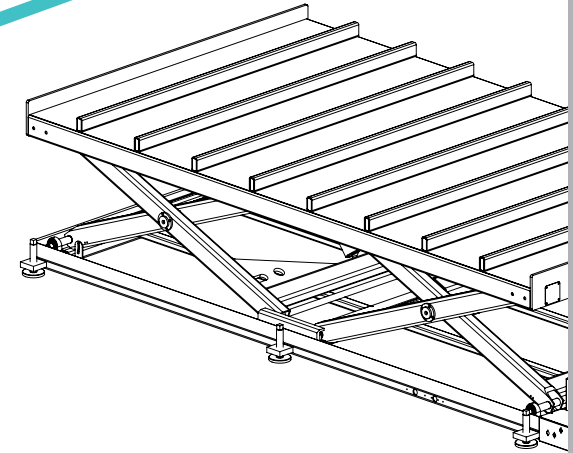



# NEXT GENERATION CONTROL CENTER

## YENİ JENERASYON KONTROL MERKEZİ

UNIDAD DE CONTROL DE ÚLTIMA GENERACIÓN

EN

The next generation control unit is powered by a PC designed for industrial operations. It allows you to make your transactions quickly and easily without getting stuck.

TR

Endüstriyel işler için üretilen PC'den gücünü alan yeni jenerasyon kontrol ünitesi. İşlemlerinizi takılmadan, hızlı ve kolay gerçekleştirmenizi sağlar.

ES

Unidad de control de nueva generación alimentada por PC fabricada para trabajos industriales. Le permite realizar sus transacciones de forma rápida y sencilla sin quedarse atascado.



### USER EXPERIENCE / KULLANICI DENEYİMİ / EXPERIENCIA DE USUARIO



"As easy to use as a mobile phone"

"Telefon kullanmak kadar kolay."

"Tan fácil como usar un teléfono"

"The machine helps us to perform machining operations accurately by guiding us with warning messages."

"Uyarılar bizi yönlendirerek, doğru işlem yapmamıza destek oluyor."

"Las alertas nos orientan y nos ayudan a realizar la acción correcta."

Our aftersales support team is always there for you when you need them thanks to the remote control feature of ALPHA.

ALPHA'nın uzaktan kontrol özelliği ile, ihtiyaç duyduğunuz her an satış sonrası destek ekibimiz yanınızda

Gracias a la función de control remoto de ALPHA, nuestro equipo de soporte posventa le apoya siempre que lo necesite.



# LANGUAGE

## 7 DİL SEÇENEĞİ

### OPCIONES DE 7 IDIOMAS

TR / EN / AR / RU / ES / FR / NL





DESIGN  
TASARLA  
DISEÑO



TRANSFER  
TRANSFER ET  
TRANSFERIR



PRODUCE  
ÜRET  
PRODUCCIÓN

# MINIMUM LOSS WITH ADVANCED PANEL OPTIMIZATION

## GELİŞMİŞ PANEL OPTİMİZASYONU İLE MINIMUM FİRE

DESPERDICIO MINIMO LA OPTIMIZACION  
DE PANELES AVANZADA

EN

Make your production with a minimum loss with panel optimization algorithm, with minimum waste.

TR

Gelişmiş panel optimizasyon motoru kesim yapılacak plakanın yerleşimini optimum seviyede, minimum fire oranı ile gerçekleştirir.

ES

El motor de optimización de panel avanzado realiza la colocación de la placa a cortar en el nivel óptimo con el mínimo desperdicio.

➤ **ERROR-FREE PRODUCTION WITH MACHINE & CUTTING SIMULATION**

➤ **MAKİNE VE KESİM SİMÜLASYONU İLE HATASIZ ÜRETİM**

➤ **PRODUCCION CORRECTA CON LA SIMULACION DE MAQUINA Y DE CORTE**

EN

You can make error-free production with part cutting simulation. With machine simulation, you can monitor axis movements, gripper and driver positions simultaneously from the control screen.

TR

Parça kesim simülasyonu ile hatasız üretim yapabilir, makine simülasyonu ile eksen hareketleri, tutucu ve sürücü pozisyonlarını kontrol ekranından eş zamanlı olarak izleyebilirsiniz.

ES

Puede realizar una producción sin errores con la simulación de corte de piezas. Con la simulación de máquina, puede monitorear los movimientos de los ejes, las posiciones de las pinzas y del conductor simultáneamente desde la pantalla de control.

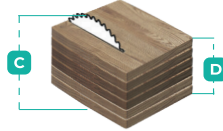
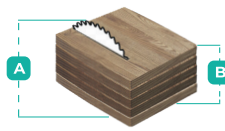
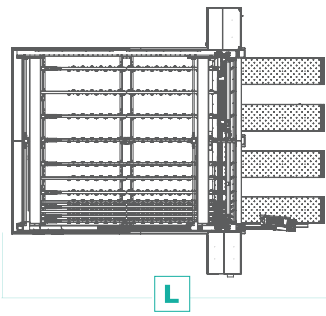

DIMENSIONS ÖLÇÜLER DIMENSIONES		L	W	H
ALPHA PS05/06 3300	mm / inch	8500 / 334.65	7370 / 290.16	
ALPHA PS05/06 3900	mm / inch	9100 / 358.27	7370 / 290.16	2185 / 86.02
ALPHA PS05/06 4300	mm / inch	9500 / 374.02	7370 / 290.16	

CUTTING HEAD KESİM YÜKSEKLİĞİ ALTO DE CORTE	ALPHA PS-05		ALPHA PS-06	
	A	B	C	D
mm / inch	105 / 4.13	90 / 3.54	120 / 4.75	105 / 4.13

TECHNICAL INFORMATION TEKNİK ÖZELLİKLER ESPECIFICACIONES TÉCNICAS	ALPHA PS-05			ALPHA PS-06		
	3300	3900	4300	3300	3900	4300
Working Area Dimensions Çalışma Alanı Ölçüleri Mediciones del Area de Trabajo	3300 mm 130"	3900 mm 154"	4300 mm 163"	3300 mm 130"	3900 mm 154"	4300 mm 163"
Main Saw Motor Power Testere Motor Gücü Potencia de Motor de Sierra	18 kW 24 HP			27 kW 36 HP		
Scoring Saw Motor Power Çizici Motor Gücü Potencia de Motor de Trazador	3 kW 4 HP					
Pusher Working Speed Çalışma Hızı Velocidad de Trabajo	80 m/dk 3149 IPM					
Saw Carriage Speed Testere Kesim Hızı Velocidad de Corte	90 m/dk 3543 IPM			90 m/dk 3543 IPM		
Cutting Saw Diameter Kesici Takım Çapı Diámetro de Herramientas de Corte	430 mm 16.93"			460 mm 18.11"		
Scoring Saw Diameter Çizici Testere Çapı Diámetro de Herramientas de Trazador	200 mm 7.87"					
Optimization Program Optimizasyon Programı Programa de Optimización	AESLUC & OPTICUT & ARDIS					
Number of Clamps Tutucu Sayısı Numero de Portadores	8 Pcs 8 Adet			10 Pcs 10 Adet		

## TECHNICAL INFORMATION

### TEKNİK ÖZELLİKLER

#### ESPECIFICACIONES TÉCNICAS

- The technical specifications and drawings provided in the catalogue are non-binding. Stock images and drawings may contain optional equipment. AES Group reserves the right to make amendments without notice.
- Katalogta bulunan teknik özellikler ve çizimler bağlayıcı değildir. Bazı fotoğraflar ve çizimler opsiyonel ekipmanları içerebilir. AES Group bilgilendirme yapmaksızın değişikliği yapma hakkını saklı tutmaktadır.
- Las especificaciones técnicas y dibujos del catálogo no son vinculantes. Algunas fotos y dibujos pueden incluir equipamientos opcionales. Grupo AES se reserva el derecho de realizar cambios sin previo aviso.

# ALWAYS WITH YOU

# DAİMA YANINIZDA

## SIEMPRE CON USTED

EN

Our expert after-sales service staff is 24/7 at your service for all your needs. For your permanent satisfaction, it provides an accurate diagnosis and intervention to all your problems as soon as possible with both instant remote connection support and on-site service. AES GROUP protects your investments with after-sales services for uninterrupted production.



### REMOTE AND ON-SITE SERVICE SERVICES

UZAKTAN VE YERİNDE SERVİS HİZMETLERİ

SERVICIOS DE MANDO A DISTANCIA Y LUGAR

TR

Uzman satış sonrası hizmet kadromuz, tüm ihtiyaçlarınız için 7 gün 24 saat hizmetinizdedir. Daimi memnuniyetiniz için, gerek anlık uzak bağlantı desteği ile gerekse de yerinde servis hizmeti ile en kısa sürede, tüm sorunlarınıza doğru teşhis sağlayarak müdahale sağlamaktadır. AES GROUP, kesintisiz üretim yapmanız için sunduğu satış sonrası hizmetler ile yatırımlarınızı korur.



### TRAINING AND INSTALLATION SERVICES

EĞİTİM VE KURULUM HİZMETLERİ

SERVICIOS DE FORMACIÓN E INSTALACIÓN

ES

Nuestro experto personal de servicio posventa está a su servicio las 24 horas del día, los 7 días de la semana para todas sus necesidades. Para su satisfacción permanente, brinda un diagnóstico preciso e intervención a todos sus problemas a la mayor brevedad posible con soporte instantáneo de conexión remota y servicio en el sitio. GRUPO AES protege sus inversiones con servicios postventa para una producción ininterrumpida.



### SPARE PARTS AND SALES SUPPORT

YEDEK PARÇA VE SATIŞ DESTEĞİ

PIEZAS DE RECAMBIO Y SOPORTE DE VENTA



### UNINTERRUPTED CONNECTION WITH WEB PLATFORM

WEB PLATFORMU İLE KESİNTİSİZ BAĞLANTI

CONEXIÓN PERMANENTE CON LAS PLATAFORMA WEB



**24/7** 0850 22 77 AES  
CALL CENTER  
CENTRO DE LLAMADAS

**CNC MACHINING CENTER (FLAT TABLE GROUP)**  
CNC İŞLEME MERKEZİ (DÜZ TABLA GRUBU)  
CENTRO DE PROCESAMIENTO CNC (GRUPO DE PLATAFORMA PLANA)

ULTRA  
SERIES U



▪ RAPTOR ULTRA



▪ EXTREME ULTRA

PRO  
SERIES P

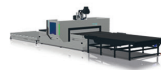

▪ SUPER NOVA



▪ FLEXA PRO

**CNC MACHINING CENTER (CONSOLE TABLE GROUP)**  
CNC İŞLEME MERKEZİ (KONSOL TABLA GRUBU)  
CENTRO DE PROCESAMIENTO CNC (GRUPO DE PLATAFORMA DE CONSOLAS)

ULTRA  
SERIES U



▪ VEGA ULTRA 5X

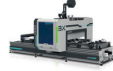

▪ VEGA ULTRA

PRO  
SERIES P

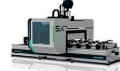

▪ VEGA 5X PRO

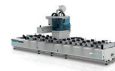

▪ VEGA PRO

**CNC DRILLING MACHINES**  
CNC DELİK MAKİNELERİ  
MÁQUINAS DE AGUJEERO CNC

ULTRA  
SERIES U



▪ GO! ULTRA

PRO  
SERIES P



▪ GO! 1300  
▪ GO! 1300 M/S  
▪ GO! 1300 M/S ATC



▪ SIRIUS 950  
▪ SIRIUS 950 M/S  
▪ SIRIUS 950 M/S ATC

**BEAM SAW MACHINES**  
PANEL EBATLAMA MAKİNELERİ  
SECCIONADORAS

ULTRA  
SERIES U



▪ ALPHA PS 05  
▪ ALPHA PS 06



▪ ALPHA PS 03  
▪ ALPHA PS 04

PRO  
SERIES P



▪ BETA PS 03  
▪ BETA PS 04

**EDGE BANDING MACHINES**  
KENAR BANTLAMA MAKİNELERİ  
CANTEODORAS MONOLATERALES AUTOMÁTICAS

ULTRA  
SERIES U



▪ GAMMA ULTRA

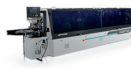

▪ GAMMA MX

PRO  
SERIES P

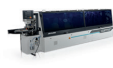

▪ PRIMA 6M  
▪ PRIMA 5M

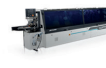

▪ GAMMA 7M  
▪ GAMMA 6M

# PRODUCTS GROUP

## ÜRÜN GRUPLARIMIZ

### GRUPO DE PRODUCTOS

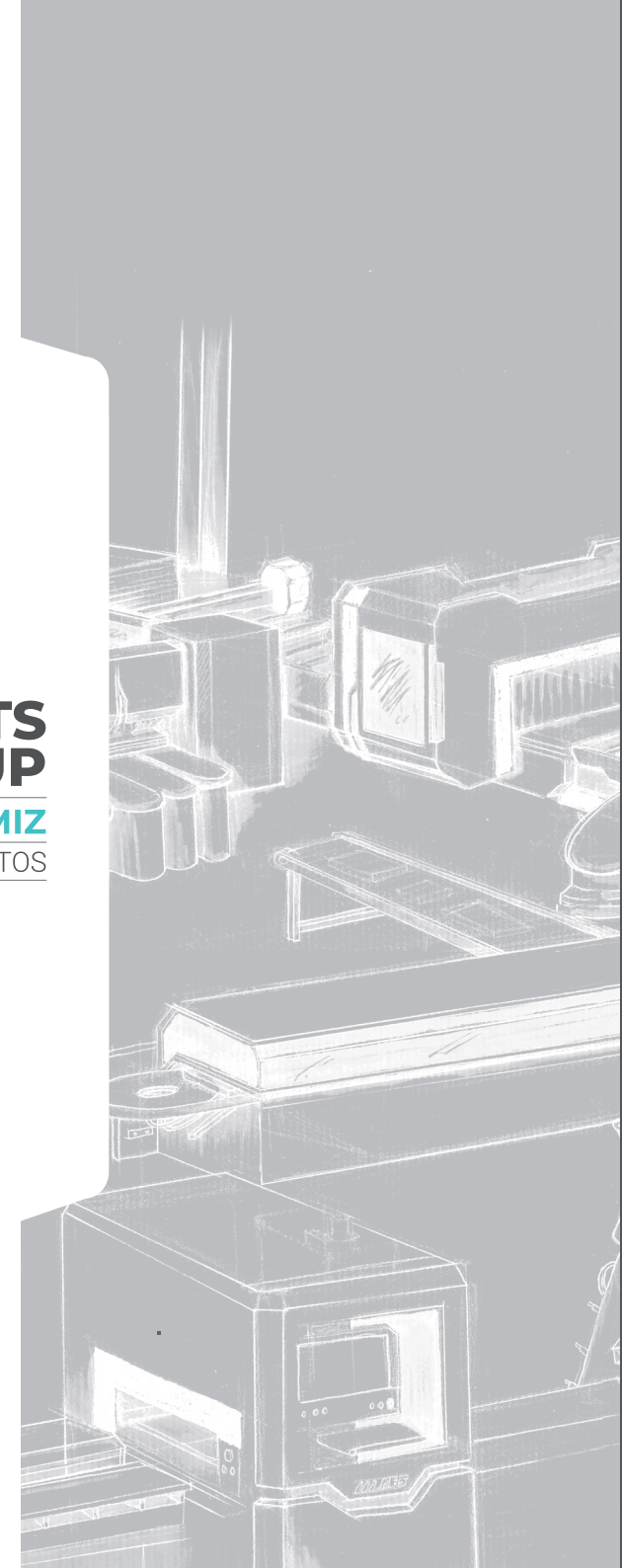

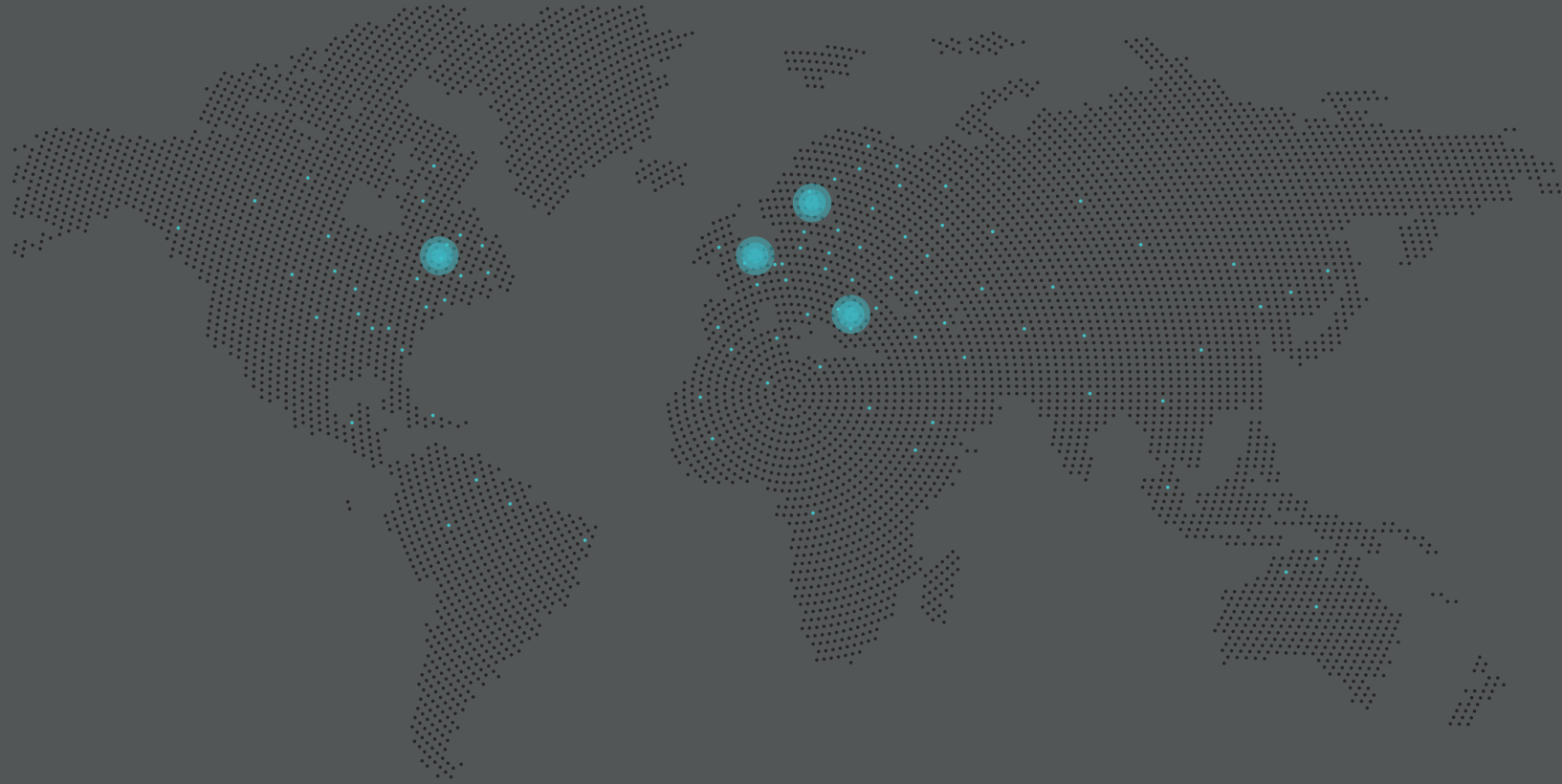

**AES HEADQUARTER**

NOSAB Şeftali Cd.  
118. Sk. No:4 Nilüfer  
16140 Bursa / TÜRKİYE

Tel : +90 224 443 33 90  
Fax : +90 224 443 29 65

info@aesgroup.com.tr  
www.aesgroup.com.tr



**AES EUROPE BVBA**

Kruisbosstraat  
2b2-6186, 3740  
Bilzen / BELGIUM

Tel : +32 89 81 1505  
Fax : +32 89 81 1505

info@aesgroupeurope.com  
www.aesgroupeurope.com



**AES AMERICA INC.**

4508-B Westinghouse  
Blvd.Charlotte, 28273  
NC USA

Tel : +1 704 817 7037  
Fax : +1 704 817 7036

info@aesgroupamerica.com  
www.aesgroupamerica.com



**AES GROUP MACHINERY UK LTD**

Unit 6, Dakota Business Park, Dakota  
Way, Burscough, Lancashire L40 8AF  
UNITED KINGDOM

Tel : +44 800 083 8844  
Fax : +44 800 083 8855

info@aesgroupukmachinery.co.uk  
www.aesgroupukmachinery.co.uk



www.aesgroup.com.tr